

Features

- Non-Magnetic
- Industry Standard Surface Mount Package
- Low Loss, High Insulation
- RoHS* Compliant

Applications

- Medical MRI Coils
- Multi Market

Description

The MADP-011136 series is a silicon PIN diode in a non-magnetic, surface mount plastic package for use as a fast switching diode. These diodes are offered with 100% matte Sn plating.

These PIN diodes feature short I-region length resulting in lower resistance, and lower capacitance devices for various VHF through S-Band control circuit applications.

The MADP-011136 series is offered as a series pair (SOT-23) and single configuration in a non-magnetic SOT-23/SOD-323 packages. The fast switching characteristics are achieved through MACOM's gold doped process.

This provides nanosecond switching and high parallel resistance in off state. These switching diodes are ideal devices used in MRI coils and other applications requiring high isolation and fast switching.

SOT-23

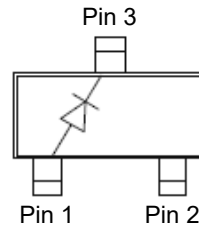

Single Configuration

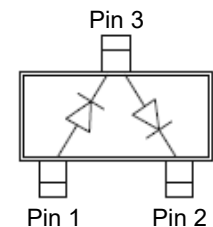

Series "T" Configuration

SOD-323

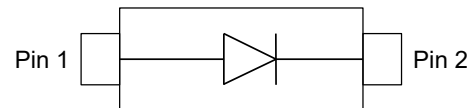

Ordering Information

Part #	Configuration	Package Cp (pF)	Package Ls (nH)
MADP-011136-N287BT	Series "T"	0.12	1.3
MADP-011136-N287T0	Single	0.12	1.3
MADP-011136-111410T	Single	0.11	0.6

* Restrictions on Hazardous Substances, compliant to current RoHS EU directive.

Electrical Specifications @ $T_A = +25^\circ\text{C}^1$

Parameter	Test Conditions	Units	Min.	Typ.	Max.
Forward Voltage	$V_F @ 1 \text{ mA}$	V	—	0.66	0.70
	$V_F @ 10 \text{ mA}$			0.79	0.85
	$V_F @ 50 \text{ mA}$			0.91	1.00
	$V_F @ 100 \text{ mA}$			0.99	1.20
	$V_F @ 150 \text{ mA}$			1.05	1.25
Voltage Breakdown	$V_B @ 100 \mu\text{A}$	V	85	180	—
Reverse Current	$I_R @ 70 \text{ V}$	μA	—	0.5	10.0
Total Capacitance	$C_T @ 0 \text{ V}, 1 \text{ MHz}$	pF	—	0.3	0.5
Reverse Recovery Time	$T_{RR} = I_F 10 \text{ mA} / I_R 10 \text{ mA}$	ns	—	5.8	—

1. Specification reflects single diode measurement.

Absolute Maximum Ratings^{2,3} @ $T_A = +25^\circ\text{C}$ (Unless Otherwise Noted)

Parameter	Rating
Operating Temperature	-55°C to $+125^\circ\text{C}$
Storage Temperature	-65°C to $+150^\circ\text{C}$
Junction Temperature	$+175^\circ\text{C}$
RF CW Incident Power: (θ die = 80°C/W), RF & DC Incident De-rating Coefficient = $-10.7 \text{ mW}/^\circ\text{C}$	+29 dBm
Total (RF + DC) Power Dissipation: (SOT-23/SOD-323): RF & DC Dissipated De-rating Coefficient = $-33.3 \text{ mW}/^\circ\text{C}$	250 mW
Reverse Voltage	Voltage Rating
Forward Current	150 mA DC

2. Operation of this device above any one of these parameters may cause permanent damage.

3. Please refer to application note M538 for surface mounting instructions.

SOD-323 (Case Style 1141)

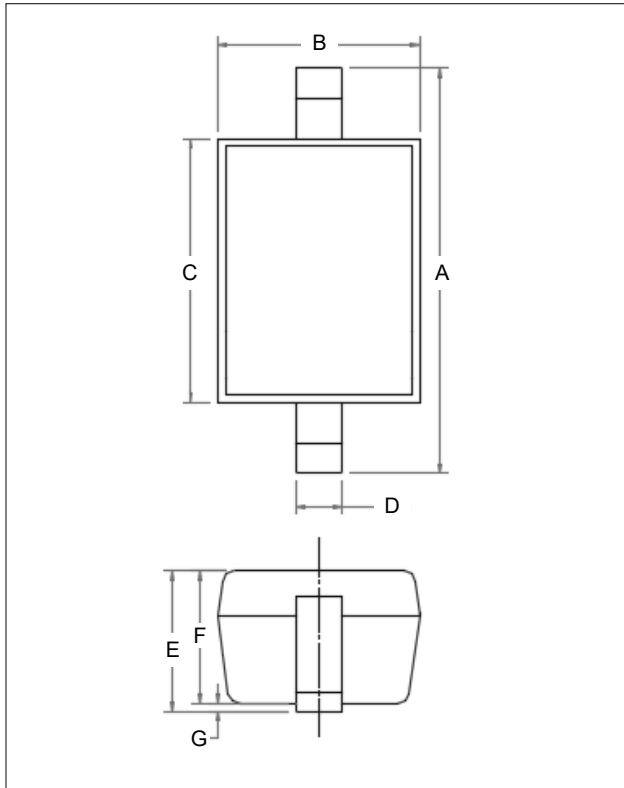

DIM.	INCHES		MILLIMETERS	
	Min.	Max.	Min.	Max.
A	0.098	0.110	2.25	2.80
B	0.0453	0.0571	1.15	1.45
C	0.115	0.128	1.60	1.80
D	0.0098	0.0157	0.25	0.40
E	—	0.0453	—	1.15
F	0.0315	—	0.80	—
G	0.0000	0.0040	0.00	0.01

SOT-23 (Case Style 287)

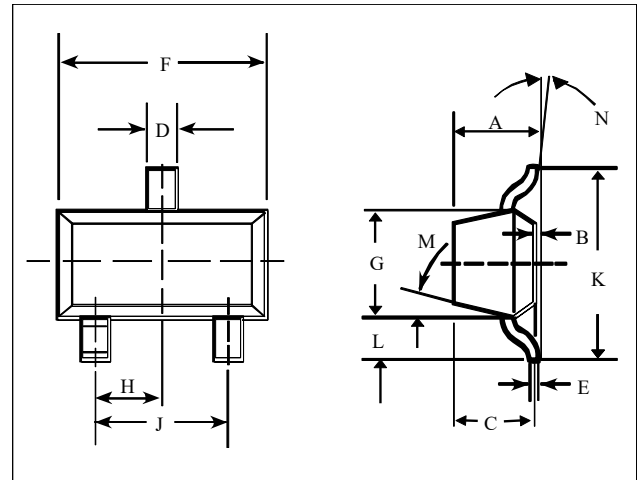

DIM.	INCHES		MILLIMETERS	
	Min.	Max.	Min.	Max.
A	3/4	0.048	3/4	1.22
B	3/4	0.008	3/4	0.20
C	3/4	0.040	3/4	1.00
D	0.013	0.020	0.35	0.50
E	0.003	0.006	0.08	0.15
F	0.110	0.119	2.80	3.00
G	0.047	0.056	1.20	1.40
H	0.037 typical		0.95 typical	
J	0.075 typical		1.90 typical	
K	3/4	0.103	3/4	2.60
L	3/4	0.024	3/4	0.60
DIM.	GRADIENT			
M	10° max.			
N	2° . . . 30°			

Mounting Information

The illustrations below indicate the recommended mounting pad configuration for the SOT-23 and SOD-323 packages. Solder paste containing flux should be screened onto the pads to a thickness of 0.005 - 0.007 inches. The plastic package is placed in position, firmly adhering to the solder paste.

Permanent attachment is performed by a reflow soldering procedure during which the tab temperature does not exceed +275°C and the body temperature does not exceed +250°C, for standard models and +260°C for the RoHS compliant devices.

Please refer to Application Note M538 for surface mounting instructions.

SOT-23 Solder Pad Configuration

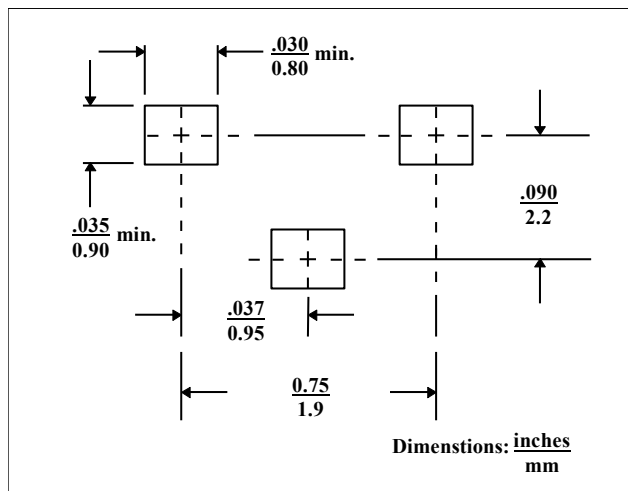

SOD-323 Solder Pad Configuration

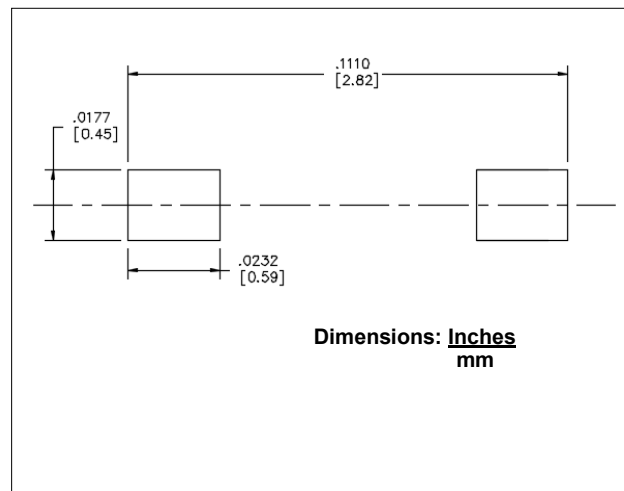

MACOM Technology Solutions Inc. ("MACOM"). All rights reserved.

These materials are provided in connection with MACOM's products as a service to its customers and may be used for informational purposes only. Except as provided in its Terms and Conditions of Sale or any separate agreement, MACOM assumes no liability or responsibility whatsoever, including for (i) errors or omissions in these materials; (ii) failure to update these materials; or (iii) conflicts or incompatibilities arising from future changes to specifications and product descriptions, which MACOM may make at any time, without notice. These materials grant no license, express or implied, to any intellectual property rights.

THESE MATERIALS ARE PROVIDED "AS IS" WITH NO WARRANTY OR LIABILITY, EXPRESS OR IMPLIED, RELATING TO SALE AND/OR USE OF MACOM PRODUCTS INCLUDING FITNESS FOR A PARTICULAR PURPOSE, MERCHANTABILITY, INFRINGEMENT OF INTELLECTUAL PROPERTY RIGHT, ACCURACY OR COMPLETENESS, OR SPECIAL, INDIRECT, INCIDENTAL, OR CONSEQUENTIAL DAMAGES WHICH MAY RESULT FROM USE OF THESE MATERIALS.

MACOM products are not intended for use in medical, lifesaving or life sustaining applications. MACOM customers using or selling MACOM products for use in such applications do so at their own risk and agree to fully indemnify MACOM for any damages resulting from such improper use or sale.